

CORNING

Pharmaceutical Glass Tubing Specifications
Definition & Supporting Information



Table of Contents

Introduction	3
General Notations	3

DIMENSIONAL

Outer Diameter	5
Circularity / Ovality	6
Inner Diameter	7
Wall Thickness	8
Wall Siding (LOP)	9
Length	10
Bow / Straightness	10
Square Cut	11
Glazing	11
End Finishing – Glazing	12

VISUAL QUALITY

Air Lines	14
Knots & Stones (Inclusions or Rough)	15
Cracks	16
Surface Impurities / Foreign Material	17
Scratches	18
Glass Particles	19
Glass Thread	19
Pit Trail / Roller Marks	20
Paneling (Waving)	20
Strain	21

APPENDICES

A. Sampling Methods and Tables	23
B. Chemical and Physical Characteristics	24
C. Traceability and Labelling — Corning Pharmaceutical Glass S.p.A. (Pisa)	26
D. Traceability and Labelling — Corning Pharmaceutical Glass, LLC (Vineland)	27
Contacting Corning Pharmaceutical Glass	28
Complaint Procedure	29

Introduction



About Corning

Corning is one of the world's leading innovators in materials science. For more than 160 years, Corning has applied its unparalleled expertise in specialty glass, ceramics, and optical physics to develop products that have created new industries and transformed people's lives. Corning succeeds through sustained investment in R&D, a unique combination of material and process innovation, and close collaboration with customers to solve tough technology challenges.

Corning Pharmaceutical Glass Tubing

Corning Incorporated operates two pharmaceutical glass tubing manufacturing sites: Corning Pharmaceutical Glass, LLC in Vineland, NJ (USA) and Corning Pharmaceutical Glass S.p.A. in Pisa, Italy. With over 160 years of experience in specialty glass and materials science innovation, Corning Pharmaceutical Glass is uniquely suited to supply high-quality clear and amber borosilicate glass tubing for use in pharmaceutical primary packaging.

Innovative Technologies

Corning has a long history of manufacturing highest-quality glass for a variety of applications. Through its sustained investment in research and development, Corning continues to innovate glass melting and forming technology. Corning Pharmaceutical Glass uses visual and dimensional quality specifications that are designed to exceed standards required for the production of pharmaceutical primary packaging. State-of-the-art furnace technologies guarantee a homogenous melting process which is monitored by control systems and regular chemical analysis.

Rigorous Process Control

From raw material preparation to final packaging, our tubing production process is seamlessly integrated. Automated computer controls maintain furnace stability and optimal melting conditions. Process variables are monitored and controlled automatically to meet specifications using online gauging equipment, which is part of a closed-loop system. This real-time process control ensures tight tolerances on key parameters such as tube OD, ID, wall thickness, siding and out-of-round.

Corning pharmaceutical borosilicate glass tubing is produced in ISO 9001:2008 certified facilities located in Vineland, New Jersey and in Pisa, Italy.

General Notations

Note 1: OD, WT, ID, OOR, WS, measurements are taken on the usable length of the tube.

Note 2: API or All Points In dimensions are available upon request.

Note 3: Diagrams may not be to scale. They are exaggerated to explain specifications and measurements.



Dimensional Quality Specifications

Outer Diameter

OD average

The average of the OD_{min} and OD_{max} :

$$OD_{ave} = (OD_{min} + OD_{max}) / 2$$

OD minimum

In any tube cross section, the OD_{min} is the minimum distance between two points on the annular cross section. This coincides with the minimum distance of two parallel lines touching the outer boundary of the annular cross section. Practically, a measurement can be obtained for any relative orientation of the cross section with respect to the parallel lines. The OD_{min} is the minimum value obtainable by orienting the tube in every direction.

OD maximum

In any tube cross section, the OD_{max} is the maximum distance between two points on the annular cross section. This coincides with the maximum distance of two parallel lines touching the outer boundary of the annular cross section. Practically, a measurement can be obtained for any relative orientation of the cross section with respect to the parallel lines. The OD_{max} is the maximum value obtainable by orienting the tube in every direction.

Outer Diameter

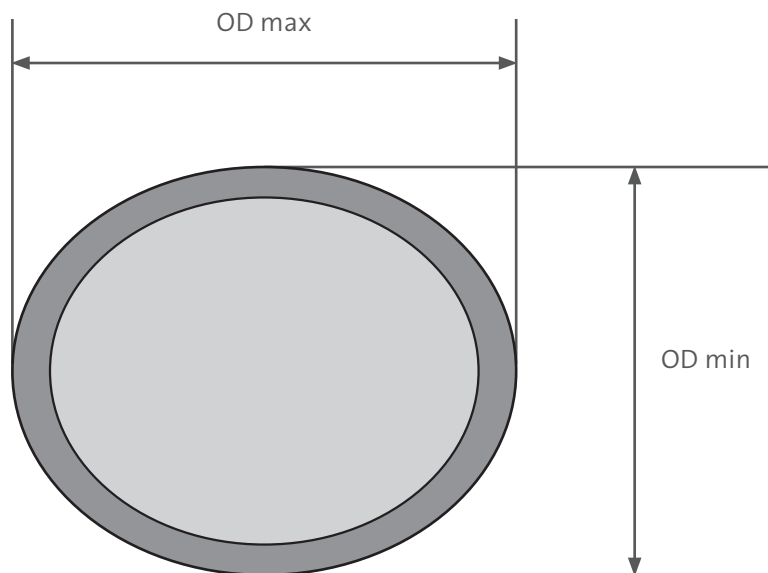

Diagrams not to scale

Circularity / Ovality

Ovality (OR)

An equivalent measurement takes the full swing of the OD, which defines the Ovality. As it is twice the circularity, the corresponding limit is also twice:

$$\text{Ovality (OR)} = \text{OD}_{\text{max}} - \text{OD}_{\text{min}}$$

Circularity (NCR)

The Circularity error is defined in any cross section as half the swing of the oriented OD:

$$\text{Circularity (NCR)} = (\text{OD}_{\text{max}} - \text{OD}_{\text{min}}) / 2$$

Ovality (OR)

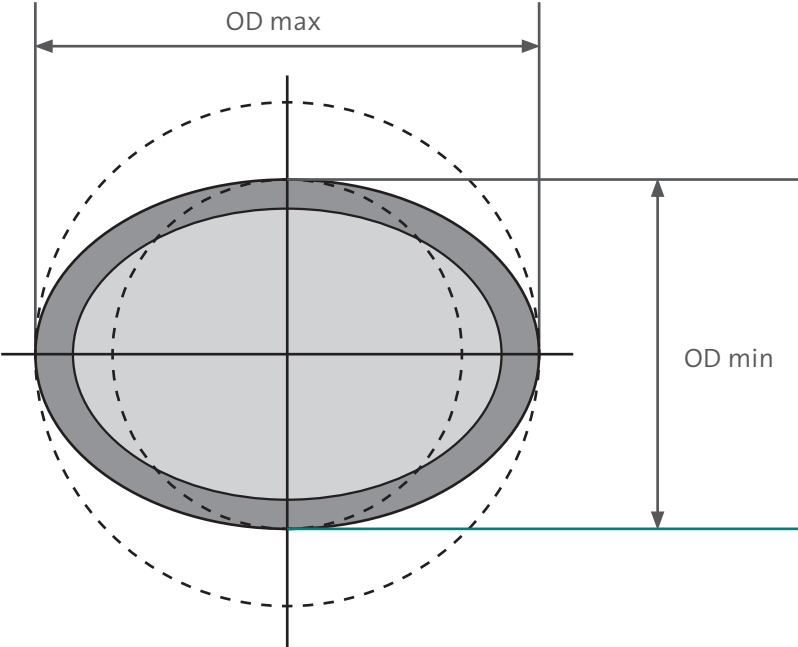

Diagrams not to scale

Inner Diameter

<u>ID ave</u>	<p>The average of the ID_{min} and ID_{max}:</p> $ID_{ave} = (ID_{max} + ID_{min}) / 2$
<u>ID min</u>	<p>The minimum distance of two parallel lines touching the inner boundary of the annular cross section.</p>
<u>Maximum Inner Diameter (ID max)</u>	<p>In any tube cross section, the ID_{max} is the maximum distance between two points on the inner surface. This coincides with the maximum distance of two parallel lines tangent to the inner boundary of the annular cross section. Practically, a measurement can be obtained for any relative orientation of the cross section with respect to the parallel lines. The ID_{max} is the maximum value obtainable by orienting the tube in every direction.</p>
<u>Notes</u>	<p>The ID_{max} and ID_{min} are obtainable by measuring with double-point snap gauge or micrometer suitable for internal measurements and rotating the tube, and then taking the max and min.</p> <p>Note: When WT (wall weight/wall thickness) is specified, ID is not applicable.</p>

Inner Diameter

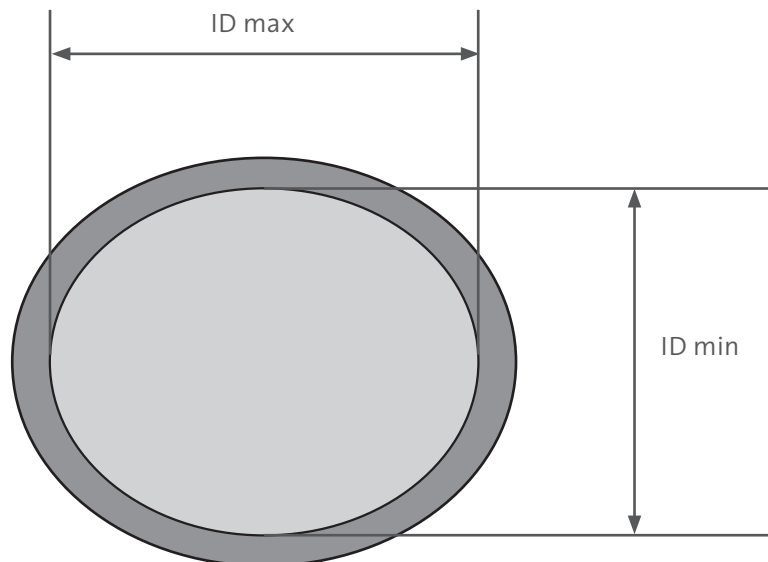

Tubing Specifications
Wall Thickness

WT ave

The average of WTmin and WTmax of a given cross section:

$$WT_{ave} = (WT_{max} + WT_{min}) / 2$$

WT max

The maximum oriented WT obtainable in a given cross section.

WT min

In any tube cross section the OD is the shortest distance between two points on the inner and outer surfaces of the tube. Practically, a local measurement can be obtained for any angular position of the external point. The WTmin of the cross section is the minimum of such values.

Wall Thickness

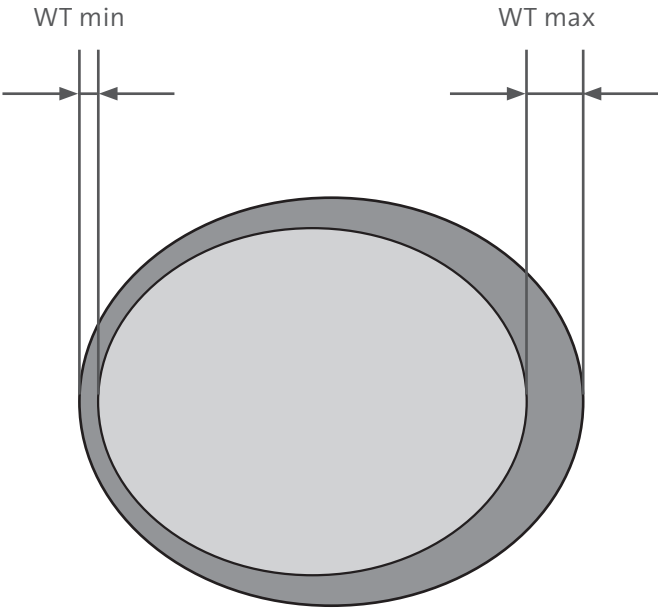

Diagrams not to scale

Wall Siding (LOP)

Wall Siding (LOP)

The Wall Siding is the difference between the maximum and minimum Wall Thickness on a cross section of the tube:

$$LOP = WT_{max} - WT_{min}$$

Notes

The WTmin and WTmax are practically obtainable by magnetic gauge with bead or with dial gauge with mandrel, the sample is rotated to obtain the max and min Wall Thickness. Wall Siding maximum acceptable value is specified depending on the nominal Wall Thickness, usually as a percentage of same.

When ID is specified, WT is normally not specified. The Wall Siding (LOP) requirement instead, applies anyway.

Wall Siding (LOP)

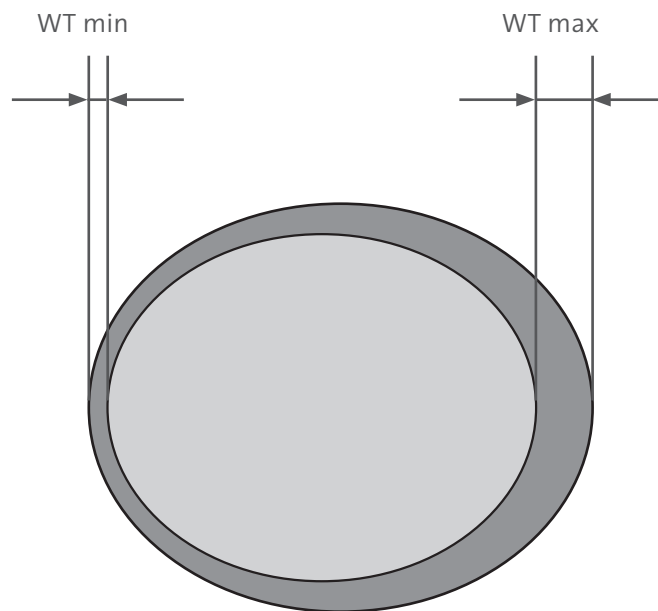

Length

Length The maximum distance between two planes perpendicular to the tubing axis, touching both tube ends.

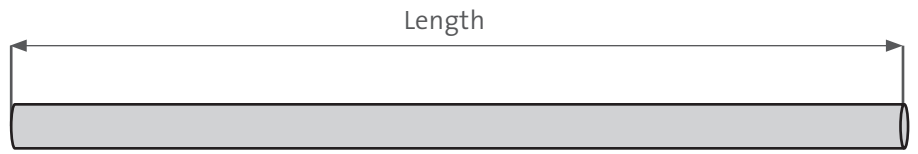

Bow / Straightness

Bow (B_{center}) The Straightness is defined as longitudinal curvature of the tubing, and is measured at the maximum deviation from a straight line over 1000 mm length of the tube.

Notes The Bow is obtained by laying the tube on two supports, 1000 mm apart from each other, and measuring half the swing of the position of its mid section axis, when it is rotated at least one complete turn around its axis.

Snaky Bow (B_s) After initial visual observation, measurement is defined as longitudinal curvature of the tubing, and is measured at the maximum deviation from a straight line over agreed upon length of the tube as stated in individual agreed upon specifications.

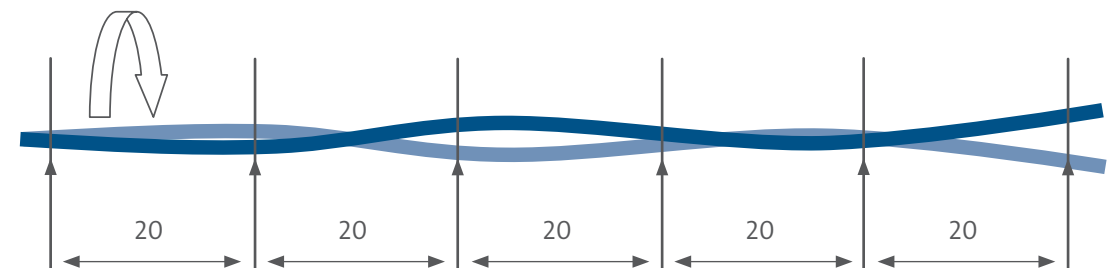
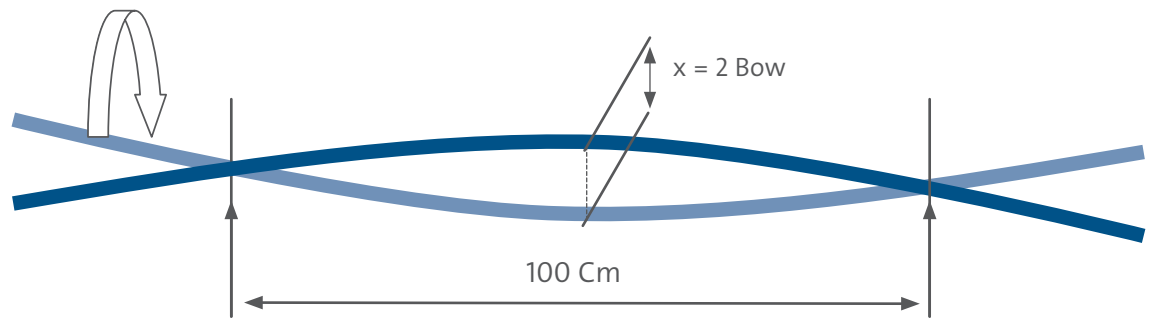

Square Cut

Square Cut (SC)

The Square Cut of a defined tube end, is the greatest absolute difference between two parallel planes, perpendicular to the tube axis, enclosing the whole end rim of the tube end. The end rim is defined by the point of contact of a linear probe, mounted perpendicularly to the tube axis and parallel to the tube radius, while the tube is rotated 360°.

Every tube provides two measurements of the Square Cut, one on each end.

Notes

The tube shall not translate along its axis while it rotates. This can be ensured by keeping the opposite end in contact with a suitably wide reference plane, perpendicular to the tube axis.

The Square Cut limit may be specified as a percentage of the nominal OD.

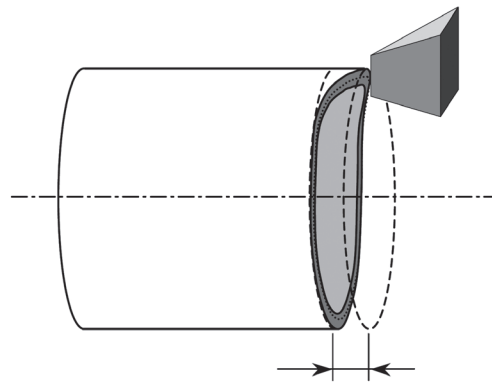

Diagrams not to scale

Glazing

End Taper (ET)

The End Taper of a defined tube end, is the distance between tube end and tube section where the OD_{max} is:

$$OD_{ET} = OD_{max} (50mm) - OD_{tol}$$

Notes

Only for Customer-specific agreements.

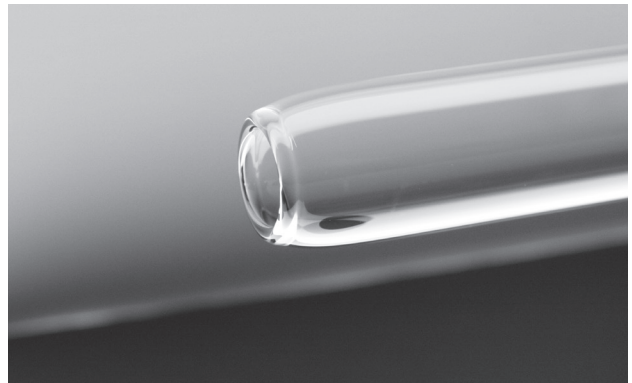
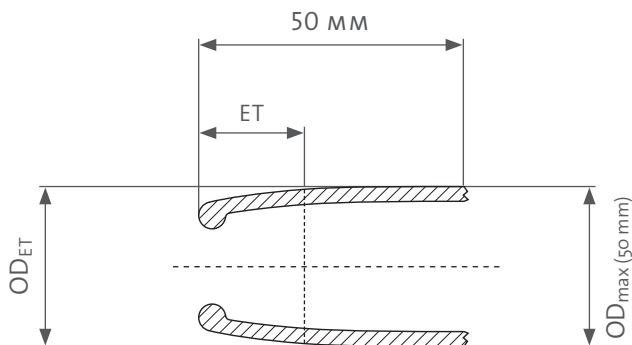

End Finishing — Glazing

Glazed ID
(GID max)

The Glazed ID of a defined tube end, is the internal diameter measurement that can be taken at the glazed tube end.

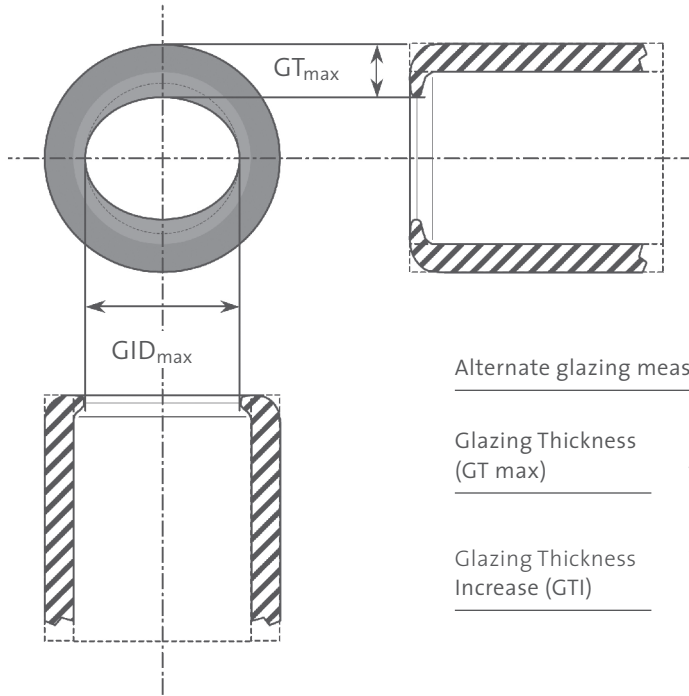

Alternate glazing measurements:

Glazing Thickness
(GT max)

The Glazing Thickness of a defined tube end, is the maximum thickness of glazing measurable at one end along a radius.

Glazing Thickness Increase (GTI)

The Glazing Thickness Increase is defined as the increase in thickness due to glazing with respect to the WT at the same point.

Diagrams not to scale

End Finishing — Glazing

Light

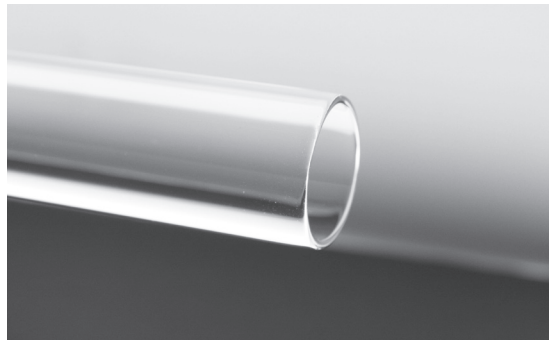

Medium

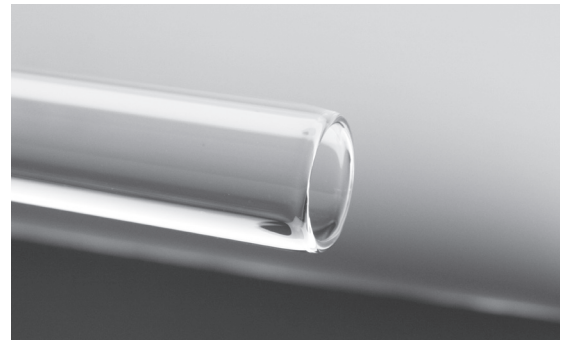

Heavy

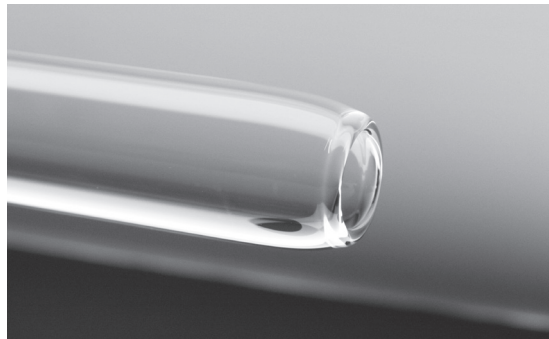

Bottoming

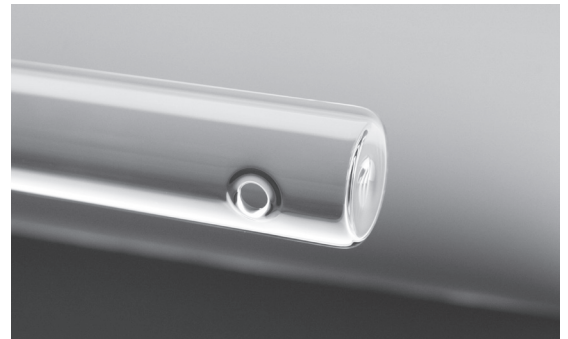



Air Lines

Definitions	<u>Closed Airline</u>	The elongated gaseous inclusion in the tubing, completely surrounded by glass.
	<u>Open Inside Airline</u>	The elongated cavity in the tubing that physically breaks the inner surface.
	<u>Airline Width (W)</u>	The Airline Width is the maximum width over the whole airline as apparent from outside the tube.
	<u>Aggregate Length %</u>	The Aggregate Length is the fraction of tubing length which is occupied by airlines, expressed in a percentage. It is the sum of the lengths of all airlines exceeding a certain dimension (Length and Width thresholds), divided by the total length of tubing inspected.

Air Lines

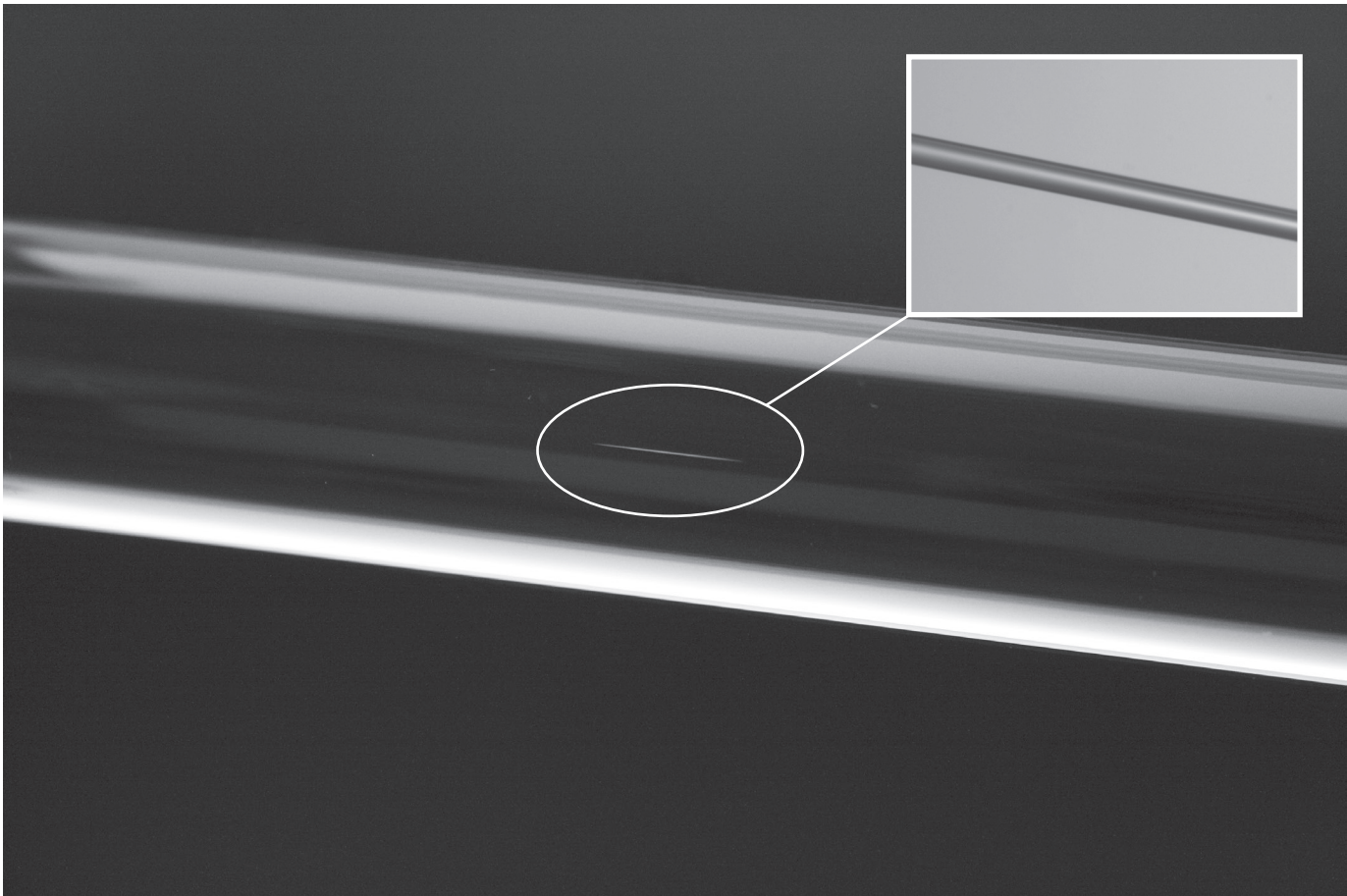

Knots & Stones (Inclusions or Rough)

Definitions	<u>Inclusion</u>	The material that differs in composition from the rest of the glass and is trapped in the glass mass. Usually shaped in a central core, which gives rise to elliptical or streaky shaped tails in the longitudinal direction.
	<u>Knot</u>	The transparent inclusion
	<u>Stone</u>	The opaque inclusion
	<u>Size (S)</u>	The Stones are the apparent diameter of the opaque core. The Knots are the apparent diameter of the transparent core, to be measured as indicated in the figures below.

Knots & Stones

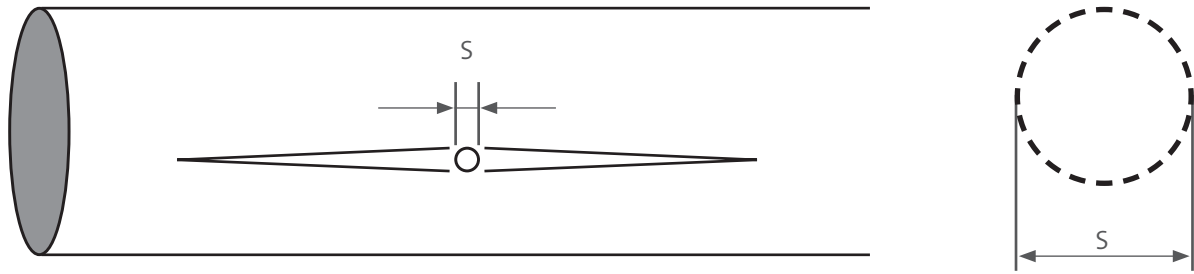

Diagrams not to scale

Knots



Stones

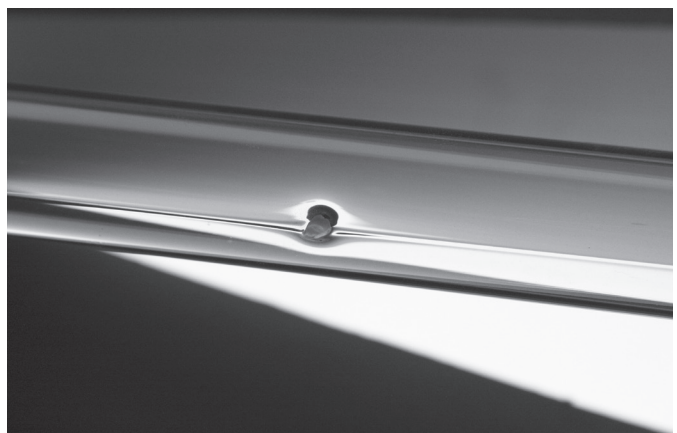

Cracks

Definitions	<u>Cracks</u>	Fractures that penetrate completely through the glass wall. Cracks significantly weaken the mechanical robustness of a tube.
	<u>End Cracks (Fissures)</u>	The cracks originating from the tube end, or entirely laying within 20 mm from the tube end.
	<u>Surface Cracks</u>	All other cracks.
	<u>Length (L)</u>	The Length of the crack line measured at the tube outer surface.

Cracks

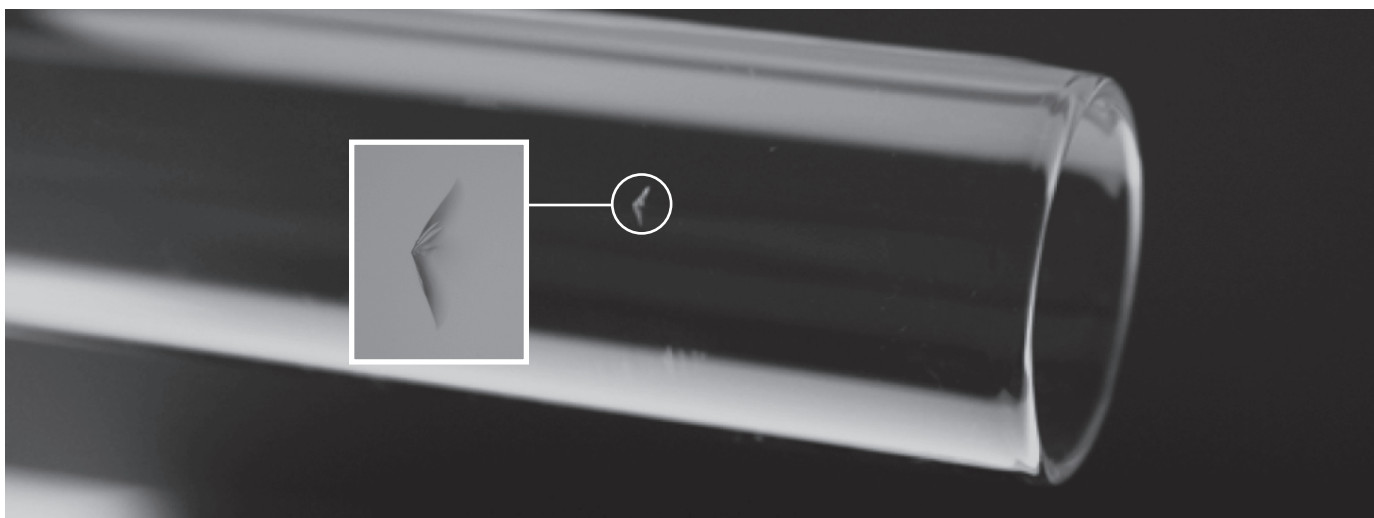

End Crack

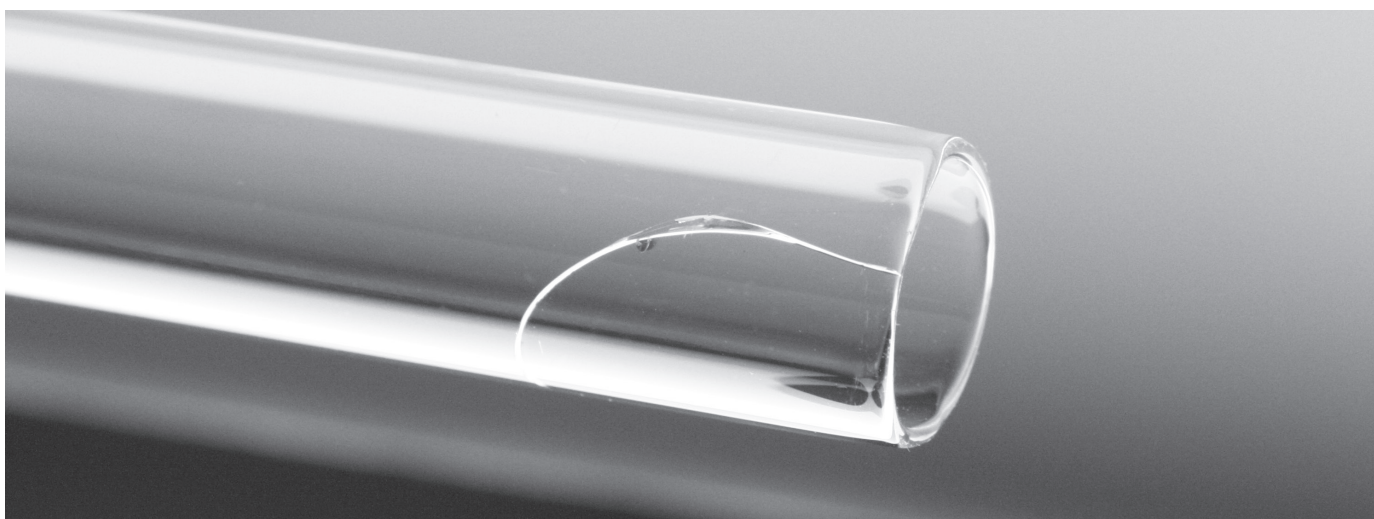

Surface Crack

Surface Impurities / Foreign Material

Definitions

Surface Impurity/
Foreign Material

This is any material adherent to the glass surface, that is foreign to the glass composition, such as dust, grease, oil, and other organic or inorganic material, which can be seen without magnification under normal lighting. Surface Impurities can be divided into different categories, such as Inner or Outer, removable or non-removable Surface Impurities (this is clarified on individual specifications).

Size (S)

The diameter (or longest dimension) of the piece of the stain or spot as visually apparent from outside the tube.

Surface impurities / Foreign Material

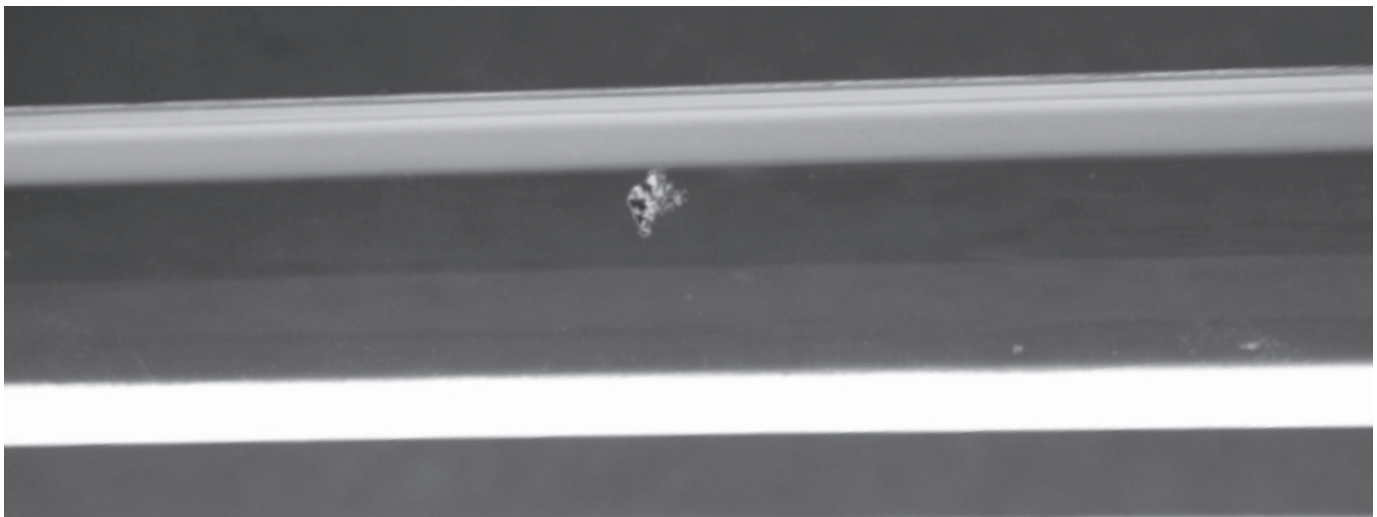
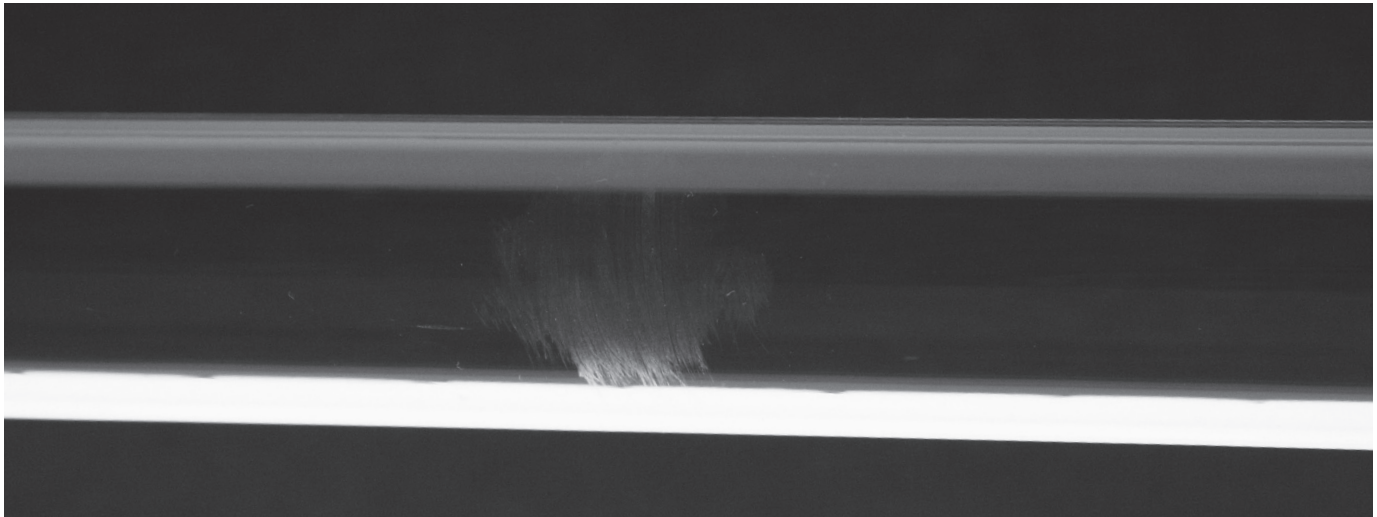

Scratches

Definitions

Scratches

The slight surface abrasions that do not penetrate the tubing wall.

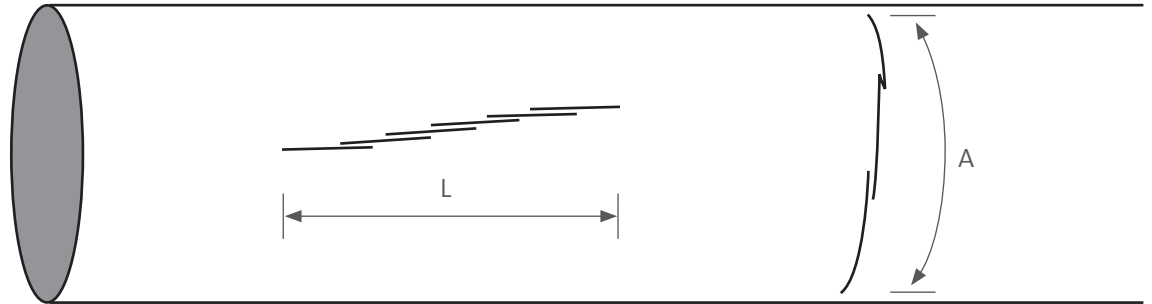

Diagrams not to scale

Size

The size is measured with respect to the longitudinal and circular dimensions of the area occupied by the scratch.

Length (L) for longitudinal scratches

Arc (A) for circular ones (fraction of circumference)

Width

The width of the single Scratch. Can be better measured by means of a 10 x microscope.

Aggregate Length

In case of multiple Scratches, the overall length (AL) shall be obtained by summing up the axial projection lengths of all Scratches wider than the specified minimum.

Scratches

Longitudinal

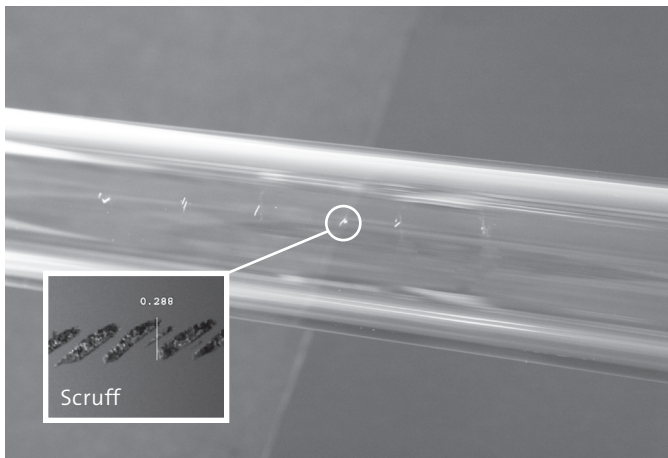

Circular

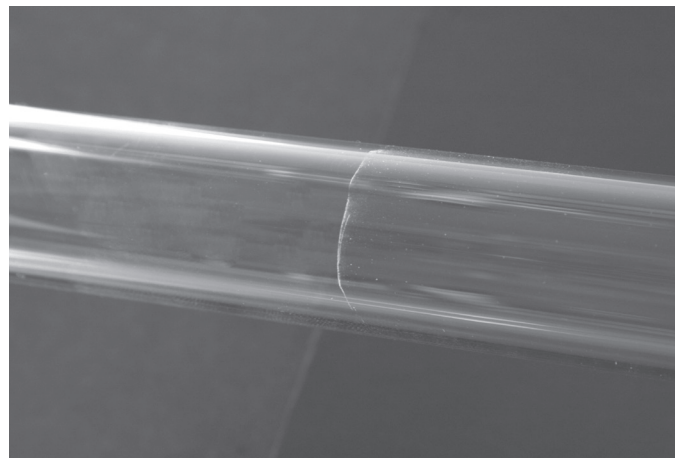

Tubing Specifications

Glass Particles

Definitions

Glass Particles

The fragments of glass inside the tube

Particle Size (S)

The diameter (or longest dimension) of the fragment as visually apparent from outside the tube.

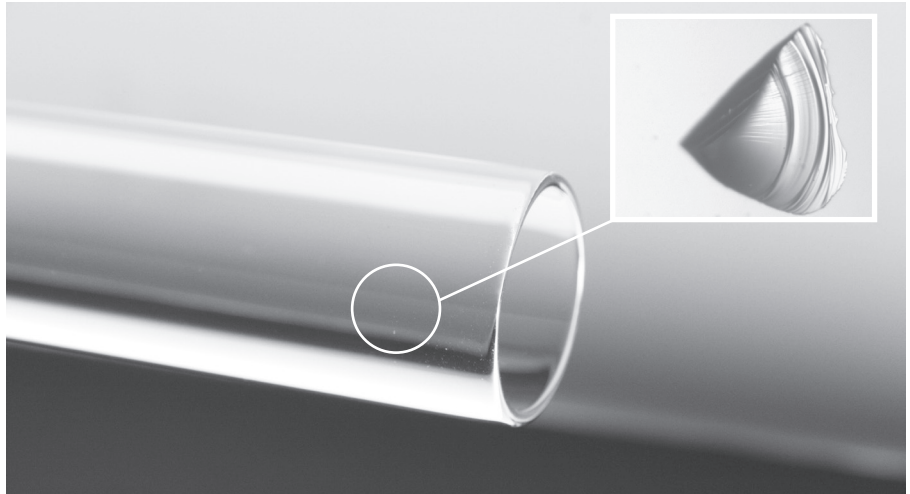

Glass Thread

Definitions

"Thread"

The elongated mass of glass, completely or partially sticking to the inner or outer surface of the tube.

Diagrams not to scale

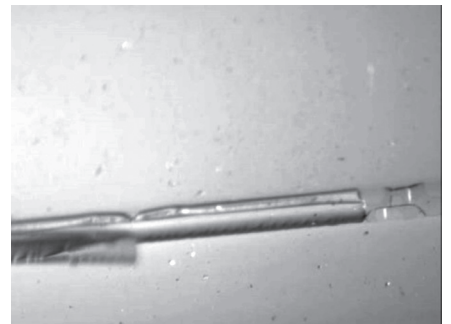
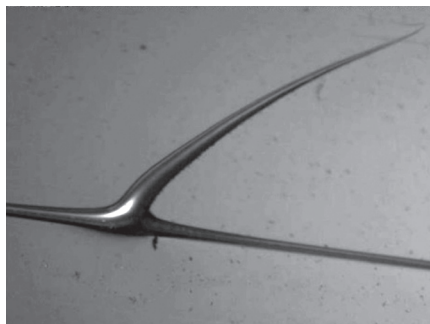
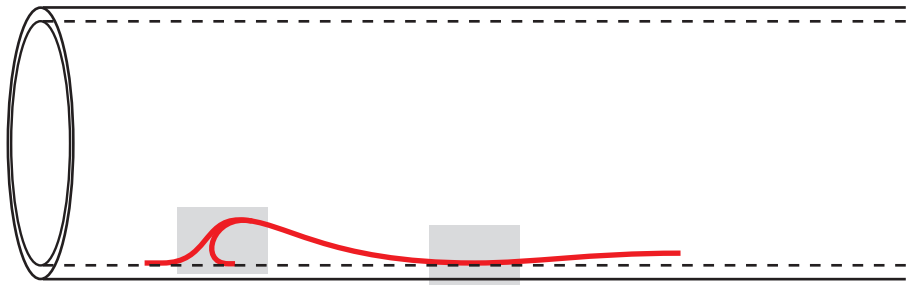

Pit Trail / Roller Marks

Definitions

Pit Trail /
Roller Marks

Dimples in the glass that are positioned in a straight line, spaced a certain distance apart.

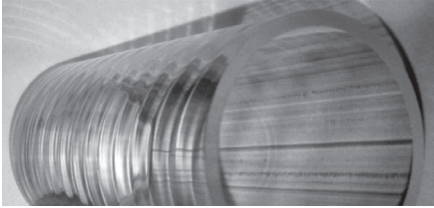
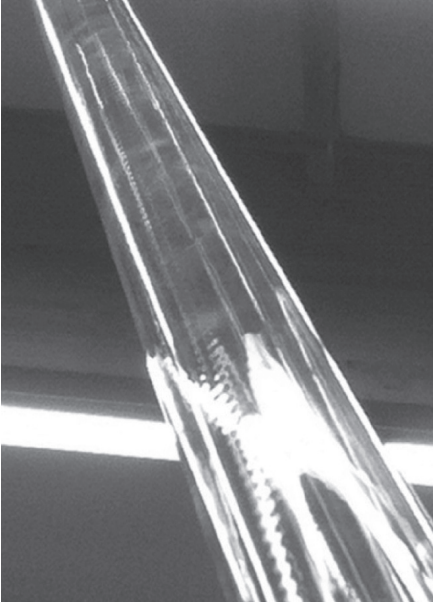

Paneling (Waving)

Definitions

Paneling
(Waving)

The deviation of the transverse optical properties from the ideal case of “uniform glass and annular cross section”, consistent along the tubing. The typical effect is the appearance of “wavy” patterns, when looking at a banded pattern in the background, across the tube, while same is being rotated.

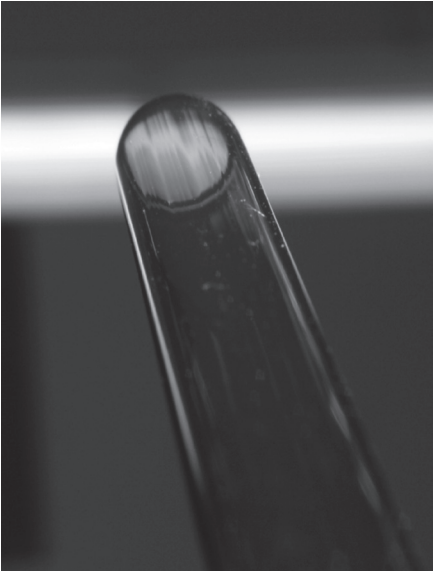

Strain

Definitions

Strain

An elastic deformation caused by tensile and/or compressive forces existing within the glass.

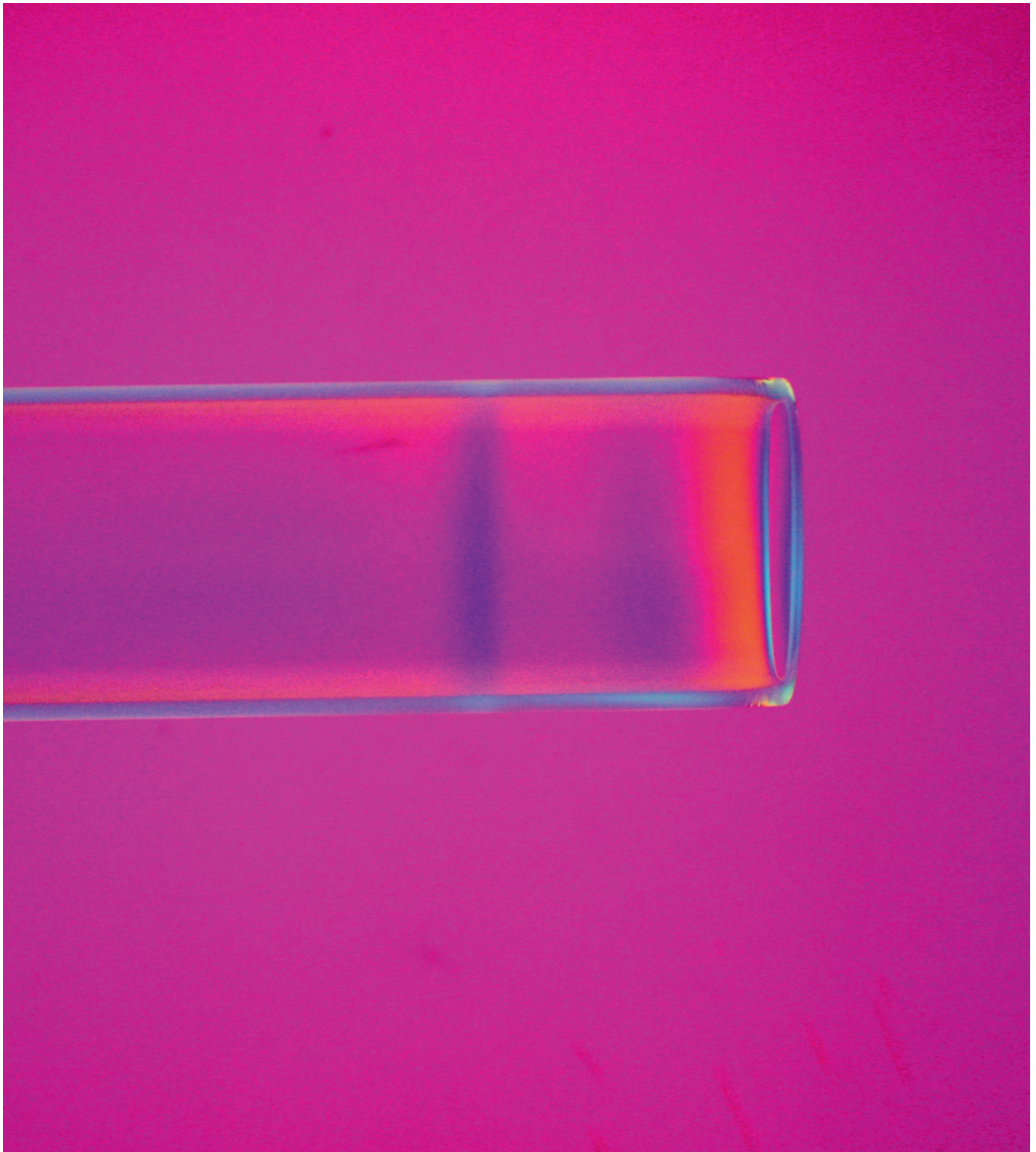



Appendices

A. Sampling Methods and Tables

Generally the Single Sampling Plan, Normal Inspection (Level II) as described in ISO 2859 is used. For the sampling plan definition, and subsequent delivery acceptance or rejection, one batch is always defined to be one pallet, while the Test Unit is defined for each defect type according to the following guidelines.

Any local deviation of same in correspondence with knots or stones or other dimensionally relevant defects, shall not be considered defect with respect to the dimensional specification.

Sampling Table										
Single Sampling Plans Normal Inspection – Level II (from ISO 2859)										
Batch Size N	AQL 0.025	AQL 0.10	AQL 0.25	AQL 0.40	AQL 0.65	AQL 1.0	AQL 1.5	AQL 2.5	AQL 4.0	AQL 6.5
from – to	n / AC	n / AC	n / AC	n / AC	n / AC	n / AC	n / AC	n / AC	n / AC	n / AC
1201–3200	500 / 0	125 / 0	200 / 1	125 / 1	125 / 2	125 / 3	125 / 5	125 / 7	125 / 10	125 / 14
3201–10000	500 / 0	125 / 0	200 / 1	200 / 2	200 / 3	200 / 5	20 / 7	200 / 10	200 / 14	200 / 21
10001–35000	500 / 0	500 / 1	315 / 2	315 / 3	315 / 5	315 / 7	315 / 10	315 / 14	315 / 21	200 / 21
35001–150000	500 / 0	500 / 1	500 / 3	500 / 5	500 / 7	500 / 10	500 / 14	500 / 21	315 / 21	200 / 21
150001–500000	500 / 0	800 / 2	800 / 5	800 / 7	800 / 10	800 / 14	800 / 21	500 / 21	315 / 21	200 / 21
► 500000	2000 / 1	1250 / 3	1250 / 7	1250 / 10	1250 / 14	1250 / 21	800 / 21	500 / 21	315 / 21	200 / 21

Batch — 1 pallet

n — Random sample size (number of testing units evaluated).

c — Acceptance figure (lot is accepted if number of defects in random sample is less than or equal to the acceptance figure).

BTU

The Basic Testing Unit (BTU or audit sample size) is a one tubing length. 5 kg random sample (500 TU of 10 grams each) should be used when Basic Testing Unit is not acknowledged under sample size.

Test Unit

1 tube. The sample must be extracted randomly as per same ISO 2859, Normal Inspection – Level II, sampling plan, from a minimum of three non-consecutive bundles. The batch size is the number of tubes in a pallet.

Test Unit

1 bundle. For evaluating packaging defects (e.g. labelling, plastic wrap), the sample will be as per same sampling plan of ISO 2859, randomly extracted from different rows of the pallet.

B. Chemical and Physical Characteristics

Glass Composition (approximate oxide weight [%])

Oxide Component	Symbol	Corning® 51-V	Corning® 51-D (*)	Corning® 51-L (Amber)	Corning® 33
Silicon Dioxide	SiO ₂	72.0	73.0	69.0	80.0
Boron Oxide	B ₂ O ₃	11.5	11.2	10.0	12.7
Aluminium Oxide	Al ₂ O ₃	6.8	6.8	6.0	2.6
Calcium & Magnesium Oxide	CaO + MgO	0.7	1.0	1.0	< 0.1
Sodium Oxide	Na ₂ O	6.5	6.8	6.0	4.3
Potassium Oxide	K ₂ O	2.4	1.2	2.0	0.1
Iron Oxide	Fe ₂ O ₃	< 600 ppm (**)	< 400 ppm (**)	1.0	< 500 ppm (**)
Barium Oxide	BaO	< 400 ppm (**)	< 400 ppm (**)	1.5	< 400 ppm (**)
Titanium Dioxide	TiO ₂	< 400 ppm (**)	< 300 ppm (**)	3.0	< 400 ppm (**)

(*) Formulated for closed ampoules / (**) Not introduced in the batch composition

Chemical Resistance Classifications

Resistance Class	Specification	Gx®51-V	Gx®51-D	Gx®51-L	Gx®33
Hydrolytic Resistance (Glass Grain)	EP (3.2.1B) / USP <660>	Type I	Type I	Type I	Type I
Hydrolytic Resistance (Glass Grain)	ISO 720	HGA1	HGA1	HGA1	HGA1
Soluble Alkali Test	JP 7.01	Complies	Complies	Complies	Complies
Acid Resistance Class	DIN 12116	Class S1	Class S1	Class S1	Class S1
Alkali Resistance Class	ISO 695	Class A2	Class A2	Class A2	Class A2
ASTM Laboratory Glass Class	ASTM E 438	Class B	–	–	Class A

Physical Properties

Name	Unit	Corning® 51-V	Corning® 51-D	Corning® 51-L	Corning® 33
Average Linear T.E.C.	10 ⁻⁷ K ⁻¹	54	51	53	32.5
Density	g cm ⁻³	2.33	2.34	2.37	2.23
Relative Refractive Index	(number) *	1.49	1.49	1.50	1.47

* λ at 587,6nm

Viscosity Curve — Characteristic Temperatures

Name	Viscosity [Poise]	Corning® 51-V	Corning® 51-D	Corning® 51-L	Corning® 33
Working Point	10 ^{4.0}	1130 °C	1155 °C	1140 °C	1240 °C
Softening Point	10 ^{7.6}	785 °C	777 °C	765 °C	825 °C
Annealing Point	10 ^{13.0}	570 °C	555 °C	550 °C	565 °C
Strain Point	10 ^{14.5}	525 °C	515 °C	515 °C	515 °C

Heavy Metals / Arsenic / Antimony

Heavy Metals

Contents of Pb, Cd, Hg, Cr^{VI} is below the 100 ppm limit value stated by the US Toxics in Packaging Clearing House (TPCH) and European Parliament and Council Directive Article 11 of 94/62/EC of 10. Dec. 1994 on packaging and packaging waste with updates 2001/171/EC and 2006/340/EC.

Arsenic and Antimony

Corning Pharmaceutical Glass does not introduce any arsenic nor antimony in the batch composition of its glasses. Tests performed as per U.S. and European Pharmacopoeia prescriptions on containers made from Corning Pharmaceutical Glass clear glass tubes give the following results:

As = Not detectable; Sb = Not detectable

B. Chemical and Physical Characteristics

Definitions	<u>Viscosity Curve</u>	The temperature at which the glass reaches some defined levels of Viscosity. Those levels are conventionally defined, and their names refer to specific steps of the transforming process (ASTM Standard Method of Test C336-71). All values are given in °C.
	<u>Working Point</u>	The temperature at which the glass is sufficiently soft to be worked (formed, blown, pressed, drawn). Log 4.
	<u>Softening Point</u>	The temperature that the glass deforms under its own weight. Log 7.6.
	<u>Annealing Point</u>	The temperature at which internal stresses, such as those caused by a rapid cooling process can be substantially eliminated in minutes. Log 13.
	<u>Strain Point</u>	The temperature where the internal stress of the glass is substantially relieved only after a matter of hours. Log 14.5.
	<u>Average Linear Expansion Coefficient (T.E.C.)</u>	The average length increase per unit length when the temperature varies from 0 to 300 °C. As the expansion coefficient is slightly affected by the annealing, reported values refer to annealed glass. Values are in K ⁻¹ .
	<u>Density</u>	The mass per unit volume. Values are in g cm ⁻³ .
	<u>Hydrolytic Resistance</u>	The resistance index of the glass to Hydrolytic attack measured on a powdered or glass grain sample. The testing methods and limits for Type 1 glass are established by international pharmacopoeias (USP, EP, JP, and those related to same).

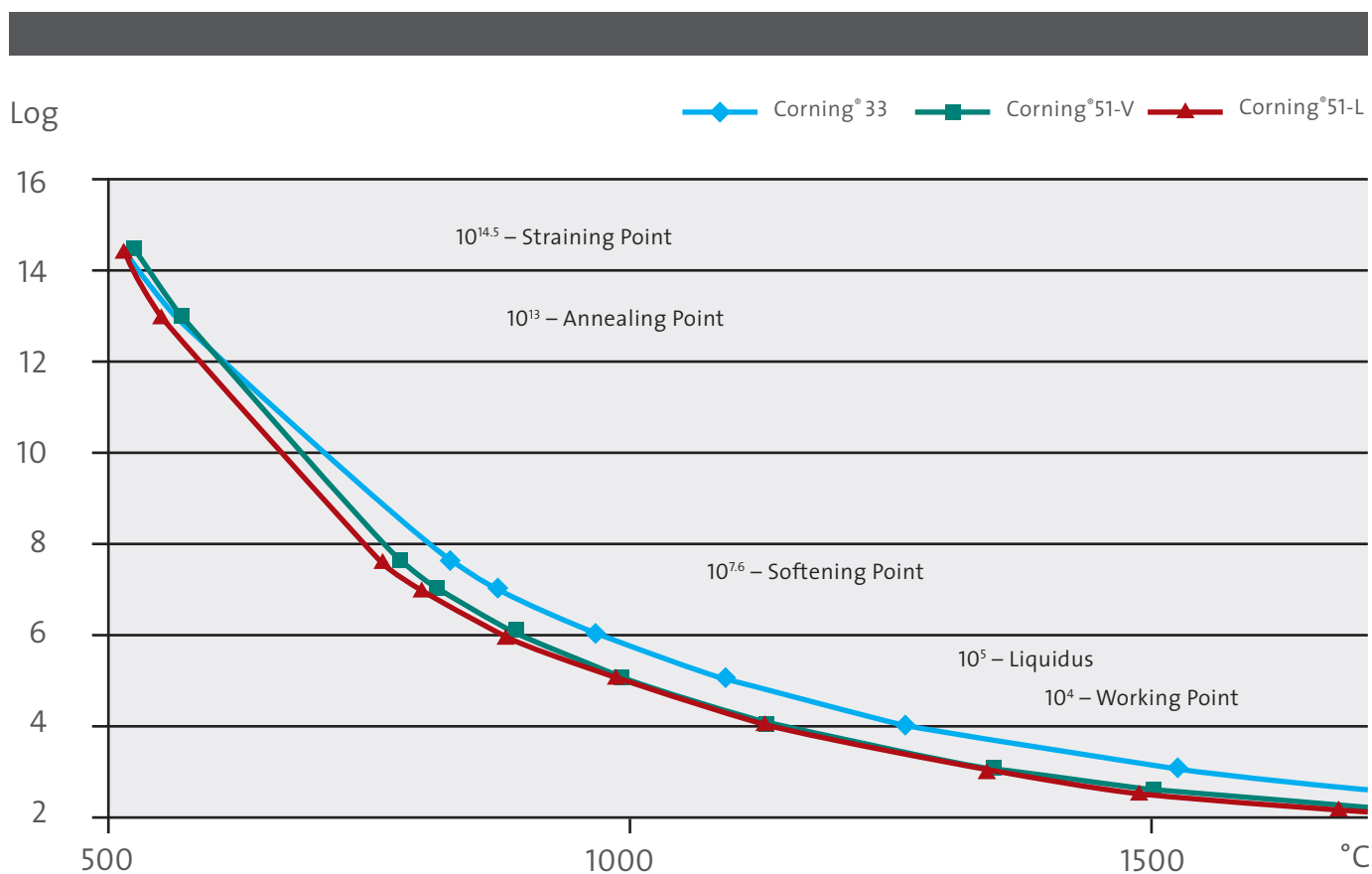

C. Traceability and Labelling — Corning Pharmaceutical Glass S.p.A. (Pisa)

Definitions	<p><u>Finished Product Lot</u></p> <p><u>Traceability</u></p> <p><u>Bundle Number</u></p>	<p>A sequence of pallets consecutively manufactured on the same line with unchanged production specifications.</p> <p>The unique six digit code Y A WW NN telling the production lot along with the bundle number. Y = Year Code A = Alley Code WW = Week Code NN = Progressive Number</p> <p>The progressive BBBB bundle number within the production lot. Complete bundle identification is therefore YAWWNN – BBBB.</p>
-------------	---	--

Bundle Label Sample

CORNING
Corning® 51-V CLEAR



8.15 mm ± 0.10

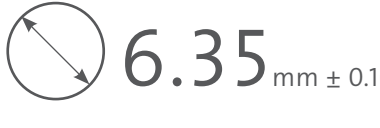

6.35 mm ± 0.10

Bundle Weight: *kg* **18.9**
lb **41.6**

Length: *mm* **1500**

Coating: **Yes**

Lot no.: **123456-7890**

Material Code:  **1234567890456**

Made in Italy

8765432118/08/1404 : 3902

← Traceability: Lot No. + Bundle No.

← Product Code

← Barcode

D. Traceability and Labelling — Corning Pharmaceutical Glass, LLC (Vineland)

Definitions	<p>Finished Product Lot</p> <hr/> <p>Traceability</p>	<p>A sequence of pallets consecutively manufactured on the same line with unchanged production specifications.</p> <p>The big label contains unique thirteen digit code MMDDYY-HHMM-S-Alley.</p>
-------------	---	---

Bundle Label Sample

CORNING
Corning® 51-L AMBER

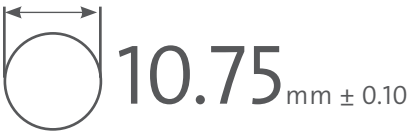

10.75 mm ± 0.10



0.50 mm ± 0.10

Bundle Weight: *kg* **15.3**
lb **33.7**

Length: *mm* **1500**

Coating: **Light**

Lot no.: **12345678** ← Lot Number

Material Code: 
1234567890456 ← Material Number with Barcode

08/16/2015 19:52 – Alley 11 ← Date, Time Stamp and Alley

Made in U.S.A.

U.S. Pallet Label Sample

Type of glass
Material dimensional specification

Corning® 51-V

Lot no.: **7024001600**

TRACEABILITY CODE: **020614 1509 4 16**

0206141509416

CUSTOMER CODE:

24.00 +/- 0.20 mm

1.000 +/- 0.040 mm

LENGTH: 60 +/- 1/4 INCHES

COATING: MEDIUM

FEB14

Net Weight **1800** LBS

Gross Weight **1896** LBS

Net Weight **816.33** KGS

Gross Weight **859.86** KGS

MADE in USA

BATCH NUMBER: FEB1401095 Lot Number: **36031502** ← Lot Number

Date when pallet was made

Time when pallet was made

Alley

Traceability

Batch Number — Month and Sequential

Contacting Corning Pharmaceutical Glass

Do not hesitate to contact our local Sales and Quality departments:

Your Needs	Corning Pharmaceutical Glass S.p.A.	Corning Pharmaceutical Glass, LLC
Sales and Delivery Information	Tel. +39 050 566614 Fax +39 050 566334	Tel. +1 856 794 5592 Fax +1 856 494 1629
	E-mail: cpginfoeu@corning.com E-mail: cpginfousa@corning.com	
Quality and Technical Inquiries	Tel. +39 050 566631 Fax +39 050 566334 Address Via Montelungo, 4 56122 Pisa, ITALY	Tel. +1 856 692 5981 Fax +1 856 691 1307 Address 563 Crystal Avenue Vineland, NJ 08360-3257, USA
	E-mail: cpgquality@corning.com	

Complaint Procedure

In case of complaints, please follow the steps below:

Identify the material by attaching the tray label or by specifying:

- Traceability Number
- Nominal Dimensions

Describe the issue:

- Kind of defect
- Describe how it was found (incoming inspection, in production, on the field)
- Quantify the frequency (pieces worked, pieces inspected, pieces defective)
- Quantify the issue: values and measurements should be obtained applying, whenever possible the definitions of this specification
- Localize the issue (in the pallet and/or in the tube) at your best

Document your findings:

- If possible, attach documents or pictures about the measured samples
- If possible, ship measured samples of suitable dimension and proper identification (including, if relevant, the position of them in the original whole tubing)

Please address the whole communication to our Quality Management Department preferably by e-mail with attachments, and ship the samples with reference to same e-mail (see the address above).

The forms found on pages 28 and 29 can be used to document any quality issues.

Complaint Procedure

Tape	Data			
Traceability				
Nominal Dimensions	+/-	+/-	+/-	
Kind of defect				
Describe how it was found	Incoming inspection		Yes	No
	In production		Yes	No
	On the field		Yes	No
Quantify the frequency	Pieces worked		N°	
	Pieces inspected		N°	
	Pieces defective		N°	
Quantify the issue	Kg		Lbs	
Localize the issue	Mark with "X" the defect position (Page 29)			
Attach documents or pictures about the measured samples				
Ship measured samples of suitable dimension and proper identification (including, if relevant, the position of them in the original whole tubing)				

Please address the whole communication to our Quality Management Department preferably by email with attachments, and ship the samples with reference to same e-mail.

Corning Pharmaceutical Glass S.p.A.

Via Montelungo, 4
56122 Pisa, ITALY

cpgquality@corning.com

Corning Pharmaceutical Glass, LLC

563 Crystal Avenue
Vineland, NJ 08360-3257, USA

cpgquality@corning.com

Localize the Complaint Issue

Please Mark with "X" the Defect Position.

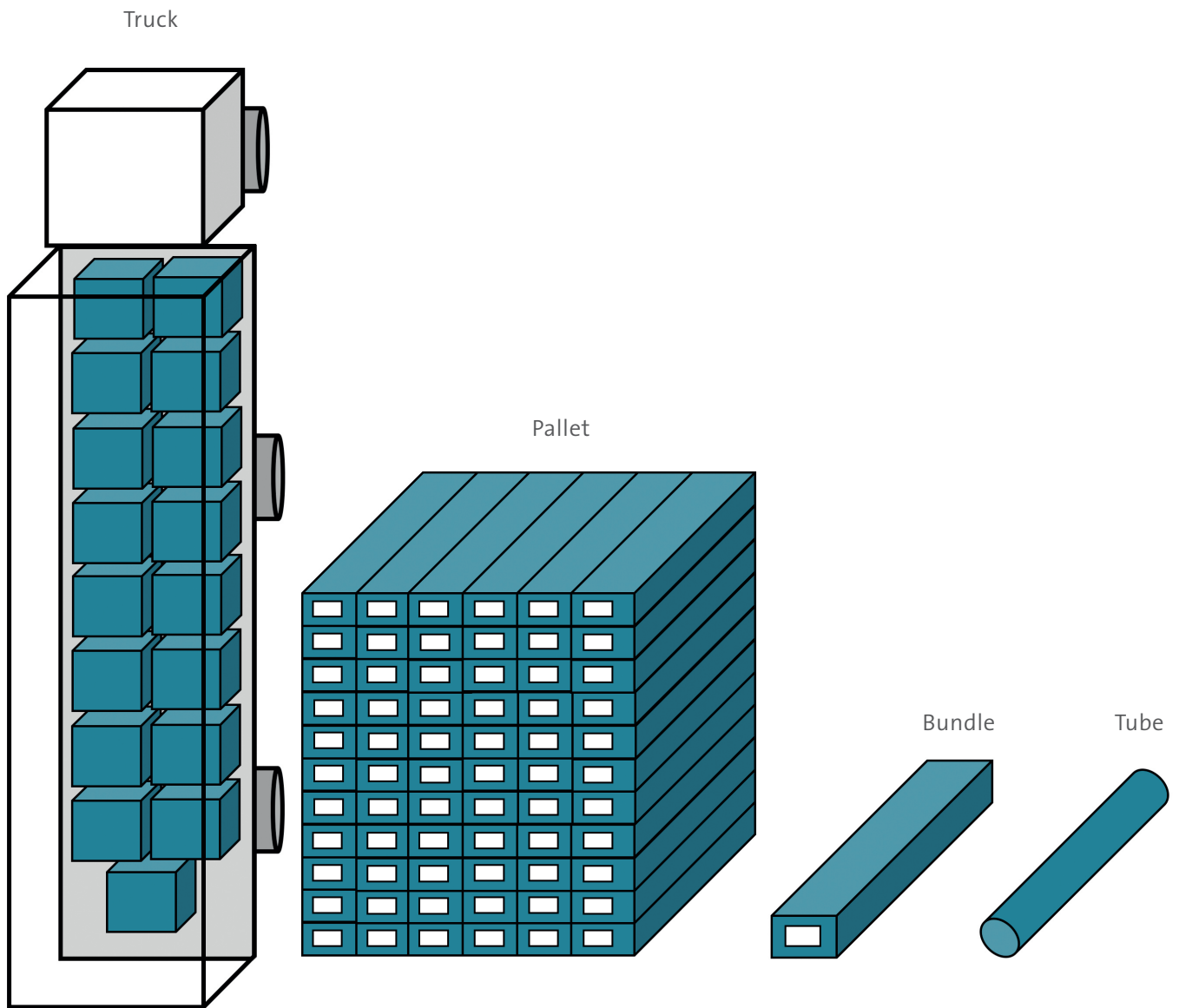

CORNING

Europe

Corning Pharmaceutical Glass S.p.A.
Via Montelungo, 4
56122 Pisa, Italy

Phone: +39 050 56 66 11
E-mail: cpginfoeu@corning.com

North America

Corning Pharmaceutical Glass, LLC
563 Crystal Avenue
Vineland, NJ 08360-3257 USA

Phone: +1 856 794 7100
E-mail: cpginfousa@corning.com

www.corning.com